

POSITION SENSING DETECTORS

Silicon photodetectors are commonly used for light power measurements in a wide range of applications such as;

- Bar-code readers,
- Laser printers,
- Medical imaging,
- Spectroscopy and more.

There is another function, however, which utilizes the photodetectors as optical position sensors. They, are widely referred to as **Position Sensing Detectors or simply PSD's**. The applications vary from human eye movement monitoring, 3-D modeling of human motion to laser, light source, and mirrors alignment. They are also widely used in ultra-fast, accurate auto focusing schemes for a variety of optical systems, such as microscopes, machine tool alignment, vibration analysis and more. The position of a beam within fractions of microns can be obtained using PSD's. They are divided into two families: **segmented PSD's** and **lateral effect PSD's**.

Segmented PSD's

Segmented PSD's, are common substrate photodiodes divided into either two or four segments (for one or two-dimensional measurements, respectively), separated by a gap or dead region. A symmetrical optical beam generates equal photocurrents in all segments, if positioned at the center. The relative position is obtained by simply measuring the output current of each segment. They offer position resolution better than 0.1 μm and accuracy higher than lateral effect PSD's due to superior responsivity match between the elements. Since the position resolution is not dependent on the S/N of the system, as it is in lateral effect PSD's, very low light level detection is possible. They exhibit excellent stability over time and temperature and fast response times necessary for pulsed applications. They are however, confined to certain limitations, such as the light spot has to overlap all segments at all times and it can not be smaller than the gap between the segments. It is important to have a uniform intensity distribution of the light spot for correct measurements. They are excellent devices for applications like nulling and beam centering.

Lateral Effect PSD's

Lateral effect PSD's, are continuous single element planar diffused photodiodes with no gaps or dead areas. These types of PSD's provide direct readout of a light spot displacement across the entire active area. This is achieved by providing an analog output directly proportional to both the position and intensity of a light spot present on the detector active area. A light spot present on the active area will generate a photocurrent, which flows from the point of incidence through the resistive layer to the contacts. This photocurrent is inversely proportional to the resistance between the incident light spot and the contact. When the input light spot is exactly at the device center, equal current signals are generated. By moving the light spot over the active area, the amount of current generated at the contacts will determine the exact light spot position at each instant of time. These electrical signals are proportionately related to the light spot position from the center.

The main advantage of lateral-effect diodes is their wide dynamic range. They can measure the light spot position all the way to the edge of the sensor. They are also independent of the light spot profile and intensity distribution that effects the position reading in the segmented diodes. The input light beam may be any size and shape, since the position of the centroid of the light spot is indicated and provides electrical output signals proportional to the displacement from the center. The devices can resolve positions better than 0.5 μm . The resolution is detector / circuit signal to noise ratio dependent.

OSI Optoelectronics manufactures two types of lateral effect PSD's. Duo-Lateral and Tetra-Lateral structures. Both structures are available in one and two-dimensional configurations.

In duo-lateral PSD's, there are two resistive layers, one at the top and the other at the bottom of the photodiode. The photocurrent is divided into two parts in each layer. This structure type can resolve light spot movements of less than 0.5 μm and have very small position detection error, all the way almost to the edge of the active area. They also exhibit excellent position linearity over the entire active area.

The tetra-lateral PSD's, own a single resistive layer, in which the photocurrent is divided into two or four parts for one or two dimensional sensing respectively. These devices exhibit more position non linearity at distances far away from the center, as well as larger position detection errors compared to duo-lateral types.

GLOSSARY OF TERMS:

Position Detection Error (PDE) or Position non-linearity is defined as the geometric variation between the actual position and the measured position of the incident light spot. It is measured over 80% of the sensing length for single dimensional PSD's and 64% of the sensing area for two-dimensional PSD's. For all calculations, the zero point is defined as the electrical center. This is the point at which $I_1 = I_2$. The error is calculated using the following equation:

$$PDE[\mu m] = \left(\frac{I_2 - I_1}{I_2 + I_1} \right) L - X \quad (19)$$

Where I_1 and I_2 are the photocurrents at the ends of the PSD, L is the sensing area half-length in μm , and X is the actual displacement of light spot from the electrical center in μm .

Percentage Position Non-linearity is determined by dividing the position detection error by the total length of the sensing area.

Interelectrode Resistance is the resistance between the two end contacts in one axis, measured with illumination.

Position Detection Thermal Drift is the position drift with change of temperature. It is the change in position divided by the total length. It is defined within 80% of length or 64% of the area for two-dimensional PSD's.

Position Resolution is defined as the minimum detectable displacement of a spot of light on the detector active area. The resolution is limited by the signal to noise ratio of the system. It depends on light intensity, detector noise, and electronics bandwidth. Position resolutions in excess of one part in ten million have been achieved with OSI Optoelectronics lateral effect PSD's.

POSITION CALCULATIONS

Segmented PSD's

Figure 12 shows a typical circuit, used with OSI Optoelectronics segmented photodiodes.

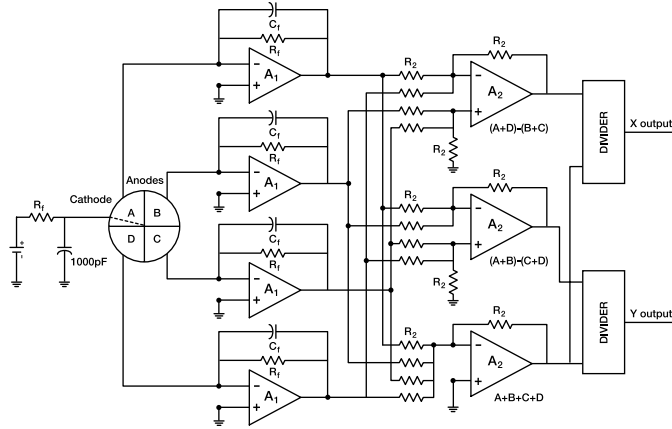

Figure 12. Typical circuit used with segmented photodiodes

The X and Y positions of the light spot with respect to the center on a quadrant photodiode is found by:

$$X = \frac{(A + D) - (B + C)}{A + B + C + D}$$

$$Y = \frac{(A + B) - (C + D)}{A + B + C + D}$$

Where A, B, C, and D are the photocurrents measured by each sector. The recommended components for this circuit are application specific. However, the following components are widely used in most applications:

Amplifiers A ₁ and A ₂ :	OPA-37 or similar
Divider :	AD-534 or similar
R _F and R ₂ :	10 kΩ to 10 MΩ
C _F :	1 / (2π R _F f)

The same circuit can be used for one-dimensional (bi-cell) measurements.

Lateral Effect PSD's

The one dimensional lateral effect measurements are the same for duolateral and tetra-lateral structures, since they both have two contacts on top with a common contact at the bottom. In tetra-lateral devices, however, the common contact is the anode with two cathodes on top, thus making them a positive current generator. In duo-lateral devices there are two anodes on top with a common cathode at the bottom. Figure 13 shows a typical circuit set up used with one-dimensional lateral PSD's.

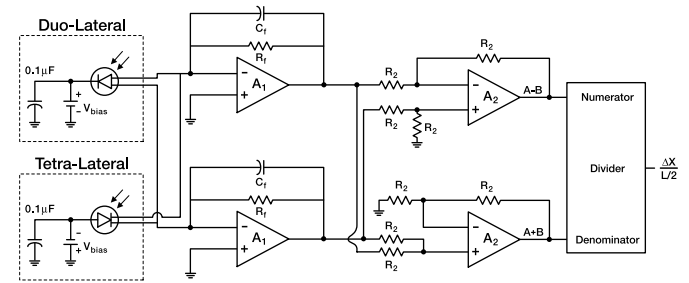

Figure 13. Typical circuit used with one dimensional lateral effect PSD's

In this configuration the outputs from the first stage are summed and subtracted in the second stage and finally divided by the divider in the final stage. The summation, subtraction and the division can be performed by software as well. The position is given as:

$$X = \frac{A - B}{A + B} \quad (21)$$

The same components as the one used in segmented photodiodes can be used with R₂ varying from 1 kΩ to 100 kΩ.

For high-speed applications, the junctions can be reverse biased with a small gain (R_F). For low frequency applications, however, the photodiode can be left unbiased and the gain (R_F), can be as high as 100 MΩ. The feedback capacitor stabilizes the frequency dependence of the gain and can vary from 1 pF to 10 μF. The gain in the first stage amplifier is I_p × R_F, and the gain of the second stage is unity.

(continued)

Two Dimensional Duo-Lateral PSD's

The two dimensional duo-lateral PSD's with two anodes on top and two cathodes on the back surface of the photodiode measure positions in two different directions, respectively. They provide a continuous position reading over the entire active area, with accuracy higher than the tetra-lateral PSD's. **Figure 14** shows a typical circuit for two-dimensional duo-lateral PSD's.

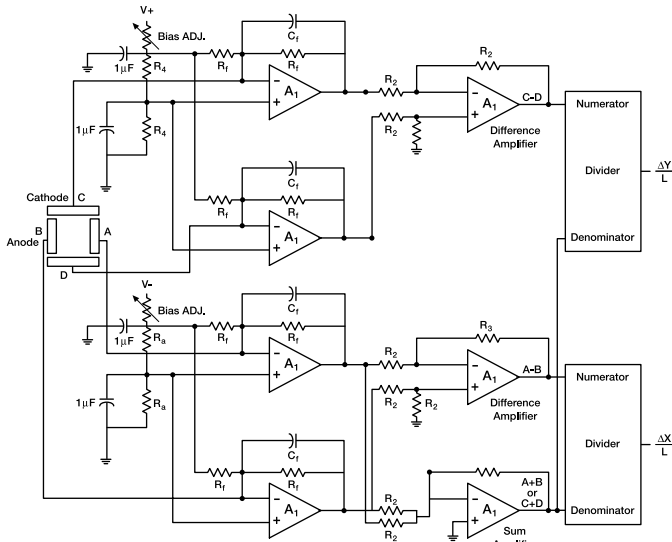

Figure 14. Typical Circuit used with two-dimensional duo-lateral PSD's

For high-speed applications, the cathodes are usually forward biased while the anodes are reverse biased. This extends the bias range that is normally limited by the maximum reverse voltage. The same components as the one-dimensional PSD's are recommended. The output is as follows:

$$X = \frac{A - B}{A + B} \quad (22)$$

$$Y = \frac{C - D}{C + D}$$

Tetra-Lateral PSD's

In a two-dimensional tetra-lateral PSD there are four cathodes and one common anode. Similar to other PSD's, the signals from the detector are converted to voltage in the first stage and then summed and subtracted in the second stage and then finally divided in the final stage. This is shown in **Figure 15**.

For high-speed applications, the anode is reverse biased and the feedback resistor (R_f) shall be chosen small. Additional gain can be achieved by additional stages. The recommended components and the output are similar to two-dimensional duo-lateral devices.

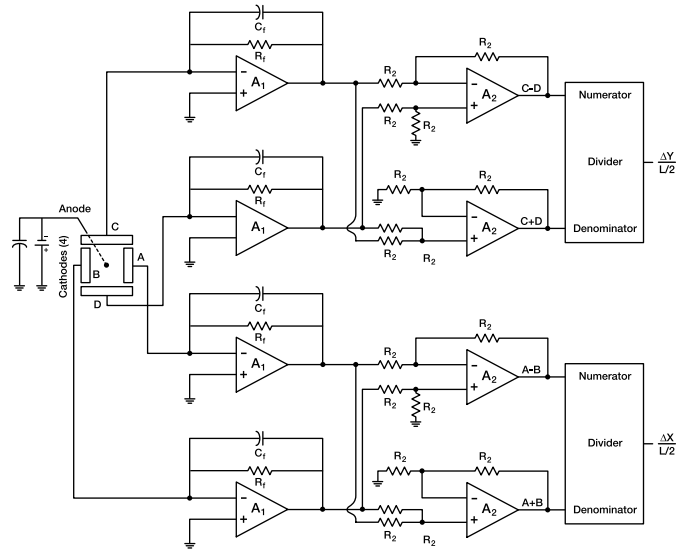

Figure 15. Typical Circuit used with two dimensional tetra-lateral PSD's